

RAMP PLAN VIEW

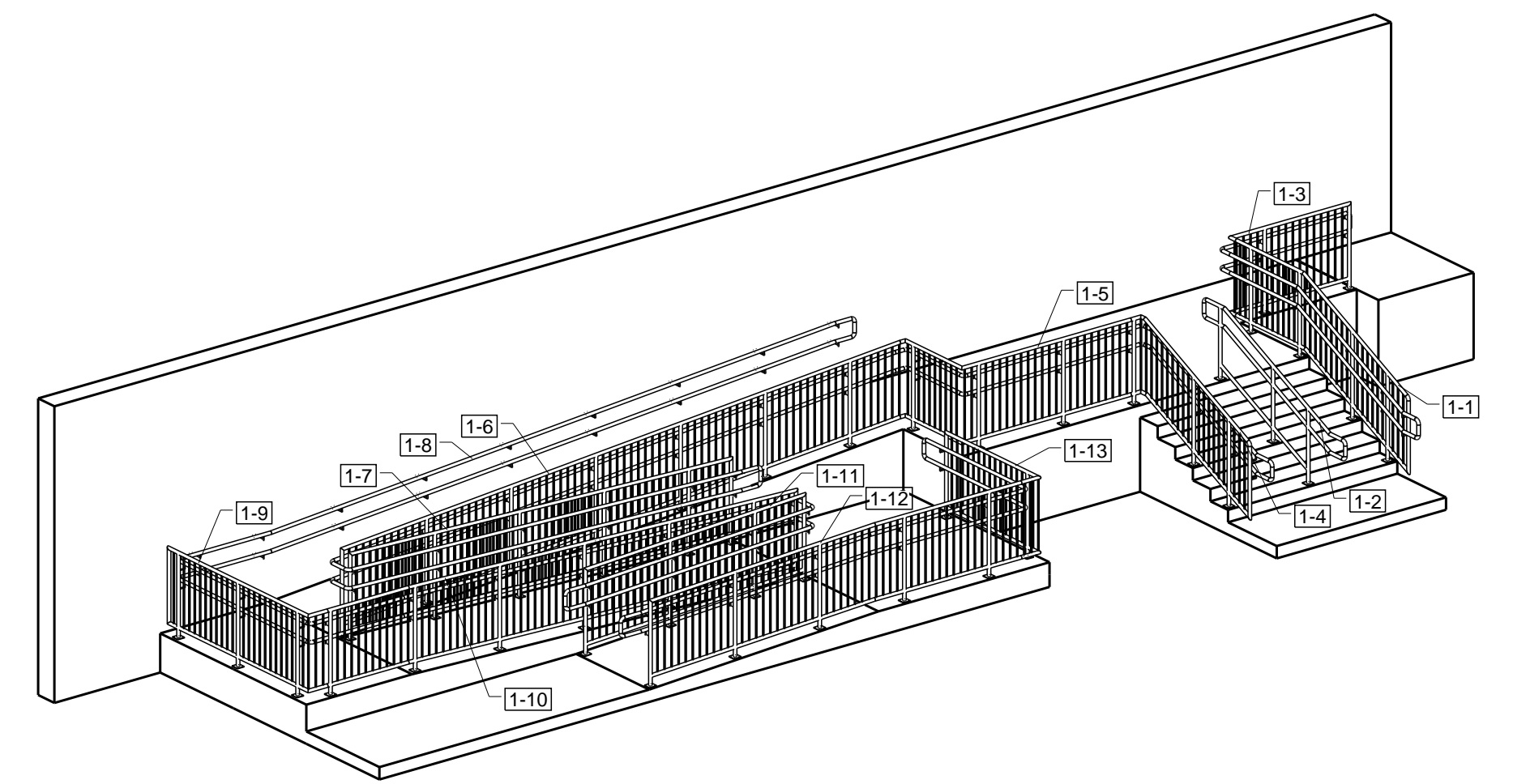

RAMP 3D VIEW

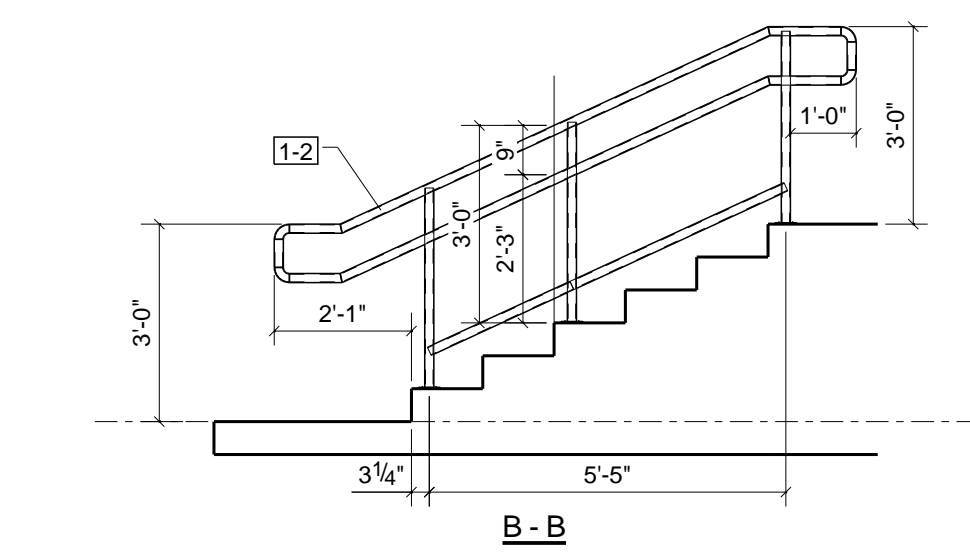

B-B

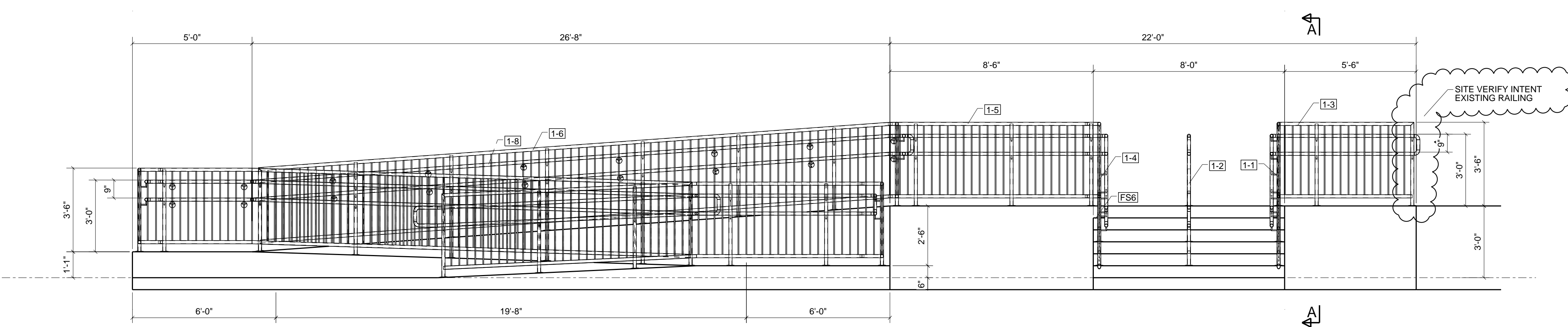

RAMP ELEVATION VIEW

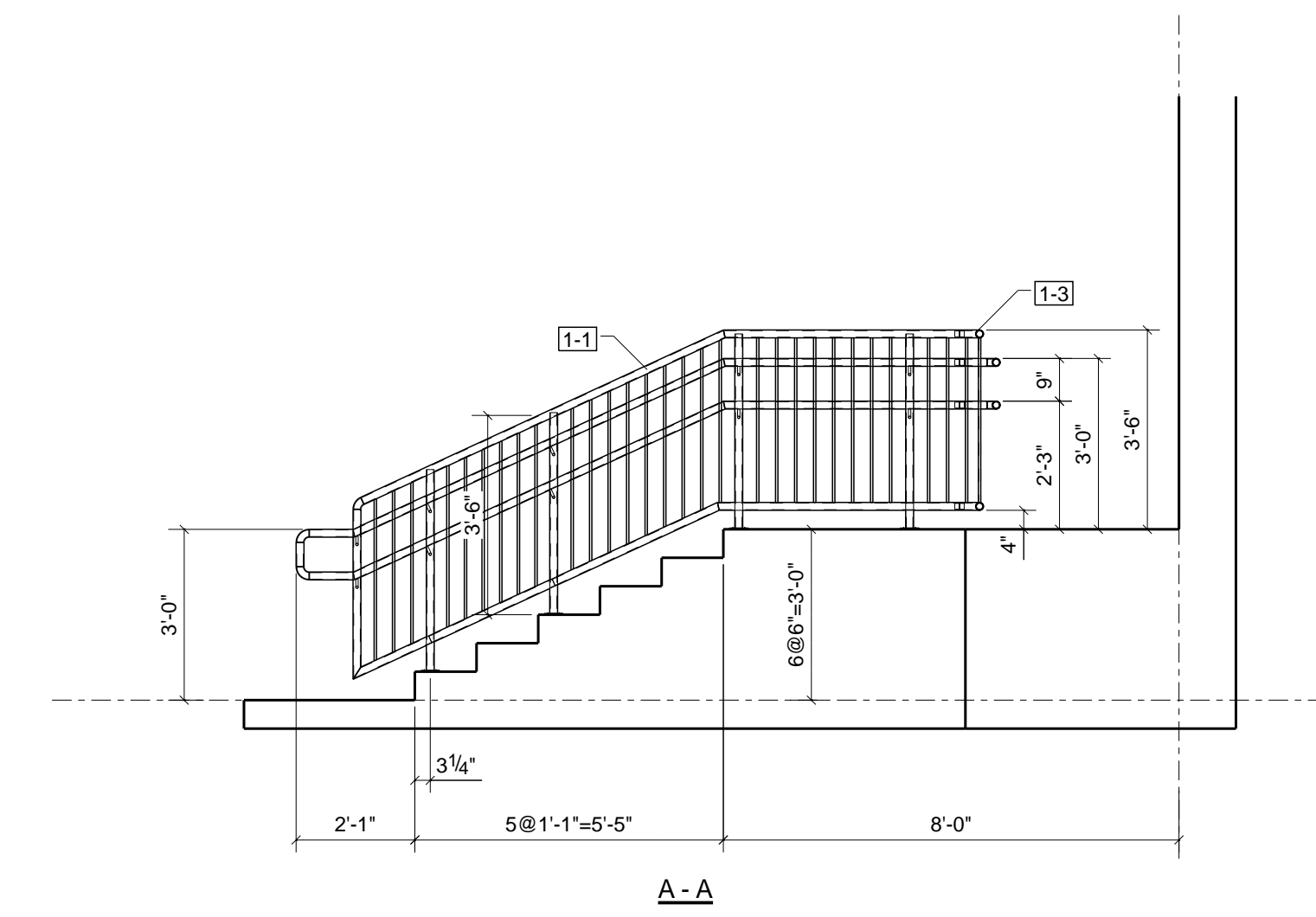

A-A

FIELD VERIFY ALL DIMENSIONS & ELEVATIONS

REFERENCE DRAWINGS: AA-201 AA-202 AA-301 AA-302	PROJECT NAME: DOOR #5 WHEELCHAIR RAMP	FELIX MOBILE WELDING WINNIPEG, MB (204)293-0035 fmw12345@hotmail.com
CONTRACTOR: Zaid Concrete & Excavting	LOCATION: CENTRAL FREIGHTHOUSE, WINNIPEG, MB	
DATE: 11/09/2016	NO: 0	DESCRIPTION: PLAN & ELEVATIONS
BY: AB	ARCHITECT: JOHN VAN LEEUWEN ARCHITECTURE & DESIGN	DATE: 11/04/2016
For Approval & Field Use	JOB NO: 2016/1002	REV: E1

DATE	NO	DESCRIPTION	BY
11/09/2016	0	For Approval & Field Use	AB